



Micropower Programmable Operational Amplifier

FEATURES

- ± 1.2 V to ± 18 V Operation
- Wide Programming Range
- Offset Null Capability
- No Frequency Compensation Required
- Low Input Bias Currents
- Short Circuit Protection

140YD1201C



K140YD12T

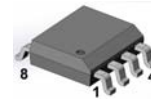

K140YD12P

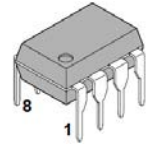

General Description

This extremely versatile operational amplifier of type 140YD12 features low power consumption and high input impedance. In addition, the quiescent currents within the device may be programmed by the choice of an external resistor value or current source applied to the I_{SET} input. This allows the amplifier's characteristics to be optimized for input current and power consumption despite wide variations in operating power supply voltages.

140YD1201 is released in TO-5, K140YD12P in PDIP-8(300Mil), K140YD12T in SOIC-8(150Mil).

Maximum Ratings

Parameter, unit	Symbol	Maximum Permissible		Limit	
		Min	Max	Min	Max
Power Supply Voltages, V	U_{CC}, U_{EE}	± 3	$\pm 16,5$	$\pm 1,5$	± 18
Common Mode Input Voltage, V (at $U_{CC} \leq \pm 15$ V, $\pm U_{IC} \leq U_{CCmin}$)	U_{IC}		± 10		± 15
Load resistance, K Ω	R_L	5		4,5	
Programming current, μ A	I_{SET}		180		200

TO-5
8-lead metal can package

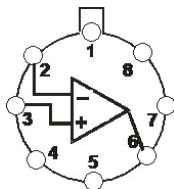

Top view



Pin Information

Pins number Package type	Symbol	Description
TO-5, SOIC-8, PDIP-8		
1	BAL1	Offset Null
2	-IN	Invert input
3	+IN	Noninvert input
4	V_{EE}	Negative supply voltage
5	BAL2	Offset Null
6	OUT	Output
7	V_{CC}	Positive supply voltage
8	I_{SET}	Programming current

SOIC-8 (150 Mil)



PDIP-8 (300 Mil)

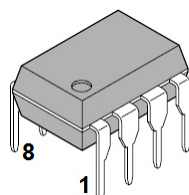



ELECTRICAL CHARACTERISTICS

Parameter, unit	Symbol	Norm		Measuring mode			
		Min	Max	U _{CC,EE} V	I _{SET} , μA	R _L KΩ	
1	2	3	4	5	6	7	
1. Maximum output voltage, V	U _{Omax}	12	-12	±15	1,5	75	
		12	-12	±15			
		13	-13	±16,5			
		1,9	-1,9	±3	15	5	
		10	-10	±15			
		12	-12	±16,5			
2. Input Offset Voltage, mV	U _{IO}	-5	5	±3	1,5	75	
				±15			
				±16,5			
				±3	15	5	
				±15			
				±16,5			
3. Supply Current, μA	I _{CC}			20	1,5	75	
				25			±15
				30			±16,5
				160	±3	15	75
				180	±15		
				200	±16,5		
4. Input Bias Current, nA	I _I			7,5	1,5	75	
				7,5			±15
				7,5			±16,5
				50	±3	15	5
				50	±15		
				50	±16,5		
5. Input Offset Current, nA	I _{IO}			-3	1,5	75	
				3			±3
				-3			±15
				-3	±16,5	15	5
				-15	±3		
				-15	±15		
				-15	±16,5		
6. Large Signal Voltage Gain	A _U			50000	1,5	75	
				100000			±3
				100000			±15
				50000	±16,5	15	5
				100000	±3		
				100000	±15		
				100000	±16,5		
7. Maximum Common Mode Input Voltage, V	U _{ICMAX}			1	1,5	75	
				-1			±3
				10			±15
				10	±16,5	15	5
				1	±3		
				10	±15		
				10	±16,5		
8. Common Mode Rejection, dB	K _{CMR}	70		±3	1,5	75	
				±15			
				±16,5			
				±3	15	5	
				±15			
				±16,5			
9. Supply Voltage Rejection Ratio, μV/V	K _{SVR}		150	±3	1,5	75	
				±15			
				±16,5			
				±3	15	5	
				±15			
				±16,5			



Continuation of Table 1

1	2	3	4	5	6	7
10. Frequency of unit gain, MHz	f ₁	0,01		±3	1,5	75
		0,01		±15		
		0,01		±16,5		
		0,1		±3	15	5
		0,1		±15		
		0,1		±16,5		
11. Slew Rate, V/μS	SR	0,01		±3	1,5	75
		0,01		±15		
		0,01		±16,5		
		0,1		±3	15	5
		0,1		±15		
		0,1		±16,5		
12. Temperature coefficient of the Input Offset Current, nA/oC	α _{IIO}	-0,4	0,4	±15	15	5
13. Temperature coefficient of the Input Offset Voltage, μV/oC	α _{UIO}	-60	60	±15	15	5

Representative Schematic Diagram

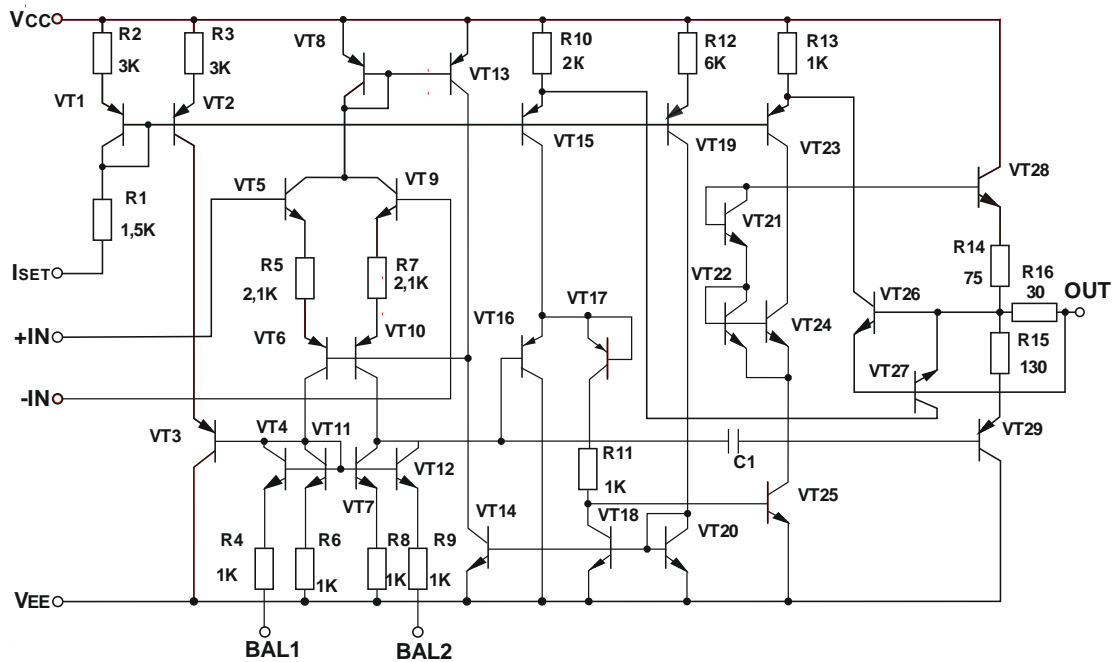

Voltage Offset Null Circuit

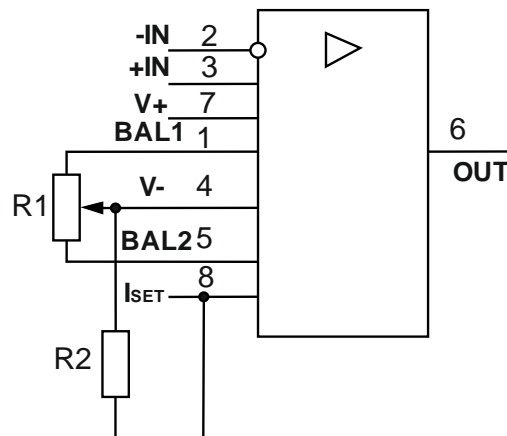

DA1 - microcircuit 140YD12;
 R1 - resistor 100 kΩ ±5%;
 R2 - resistor (Table 2).

Table 2

Power supply voltage (U _{CC}), V	Nominal value of resistor (R2), MΩ	Programming current (I _{SET}), μA	Note
±1,5	1,69	1,5	T = (25±5) °C
	0,169	15	
±3	3,61	1,5	
	0,361	15	
±6	7,5	1,5	
	0,75	15	
±15	20	1,5	
	2	15	
±18	24	1,5	
	2,4	15	

Notes

- 1 Resistor R2 is connected between terminals 4 and 8.
- 2 Nominal value of resistor R2 depends on the value of the external reference current I_{div} and the voltage U_{CC} in accordance with the formula:

$$R2 = (U_{CC}^+ + U_{EE}^- - 0,7) / I_{SET}$$

and for two values (1.5 μA and 15 μA) of the programming current is determined from Table 2.

3 It is possible to include resistor R2 between pin 8 and common point. In this case, the value of the resistor is determined by the formula: $R2 = (U_{CC}^+ - 0,7) / I_{SET}$

4 Instead of resistor R2, it is possible to use an external reference current source, for which internal resistance, determined by the formula:

$$R_{INT} \approx (25 / I_{SET} + 3,3) \text{ K}\Omega,$$

where I_{SET} is the programming current in microamperes. The voltage drop at this resistance is 0,7 V.



Dimensional drawings of the used cases

140YD1201
Bottom view

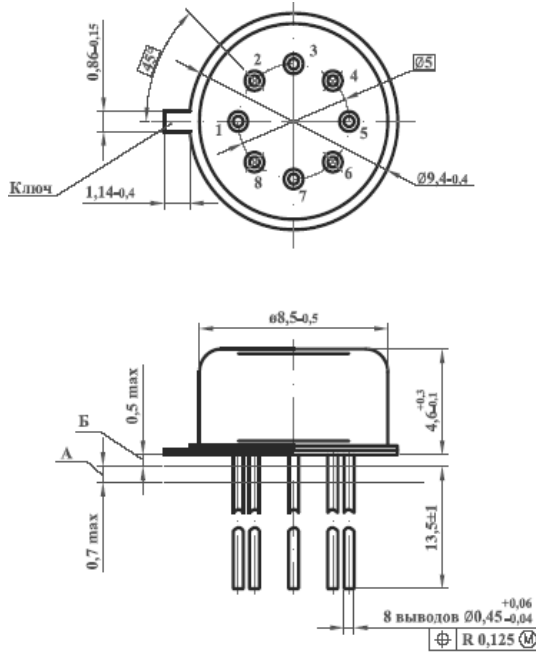

TO-5 (3101.8-1)
8-lead metal can package
Units, mm

K140YD12T

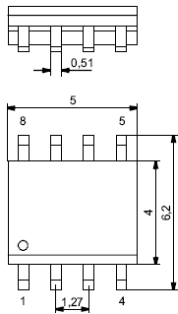

SOIC-8 (150 Mil)
Units, mm

K1463YD12P

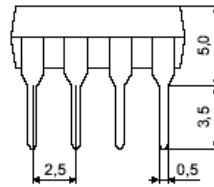

PDIP-8 (300 Mil)
Units, mm

