

### 1、 Description

The V2181 is a state-of-the-art voltage-controlled amplifier (VCA) offering high-performance current-in/current-out technology including two opposing-polarity, voltage-sensitive control ports. The V2181 VCA combines many advantages such as ultra-low noise, ultra-low distortion, low offset and high gain-bandwidth. It requires few external support circuitry and is housed in a space-efficient 8-pin single-in-line (SIP) package.

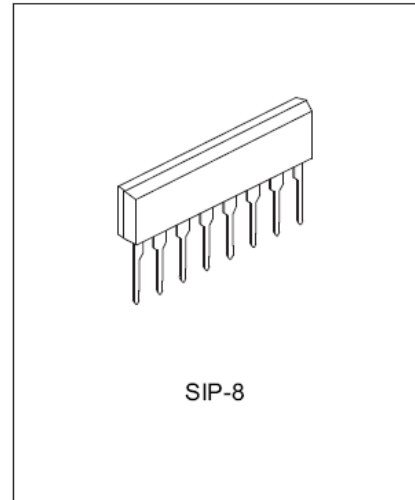

### 2、 Features

- Wide dynamic range:** >115 dB
- Wide gain range:** >130 dB
- Logarithmic gain control with dual gain control (pos/neg)**
- Low distortion:** (0.008 % @ 0 dB gain, 0.035 % @ 15 dB gain)
- Wide gain-bandwidth:** 6 MHz
- Low harmonic distortion:** 0.01 % (typ)
- Package outline:** SIP-8 (V2181)
- ROHS compliant (PB-free)**

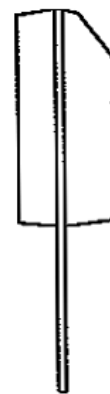
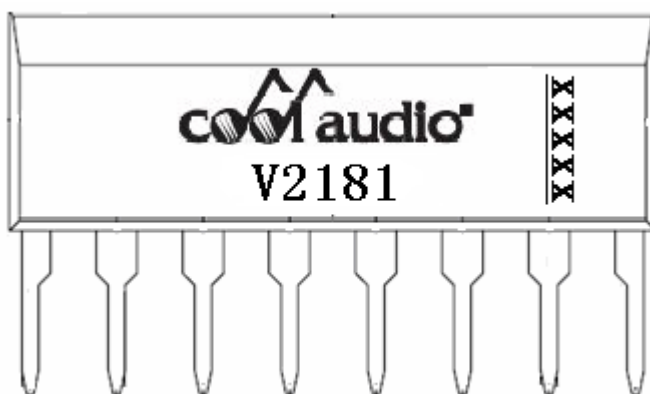

Information furnished by COOLAUDIO is believed to be accurate and reliable. However, no responsibility is assumed by COOLAUDIO for its use, nor for any infringements of patents or other rights of third parties which may result from its use. No license is granted by implication or otherwise under any patent or patent rights of COOLAUDIO.

Rev. 1.0

### 3、 Applications

- Faders
- Expanders
- Compressors
- Equalizers
- Oscillators
- Filters
- Automation Systems

### 4、 Pin Configuration

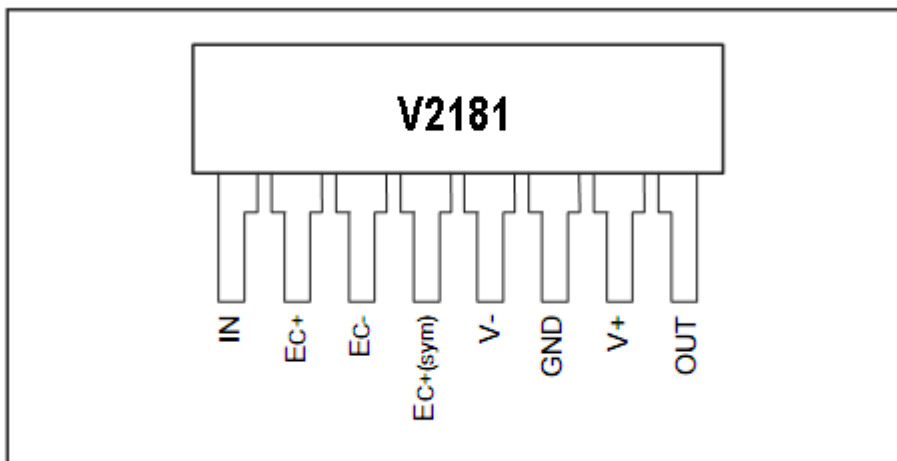

## 5、 Function Description

The V2181 VCA is designed for high performance in audio applications which requires exponential gain control, low distortion, wide dynamic range and low DC “control feedthrough” modulation. Gain is controlled by converting an input current signal to a bipolar logged voltage, adding a DC control voltage and reconvertng the summed voltage back to a current through a bipolar antilog circuit.

The simplified internal circuit diagram of the IC is shown in figure 1. The AC input signal current flows in the input pin 1, which is maintained at a virtual ground by an internal opamp.

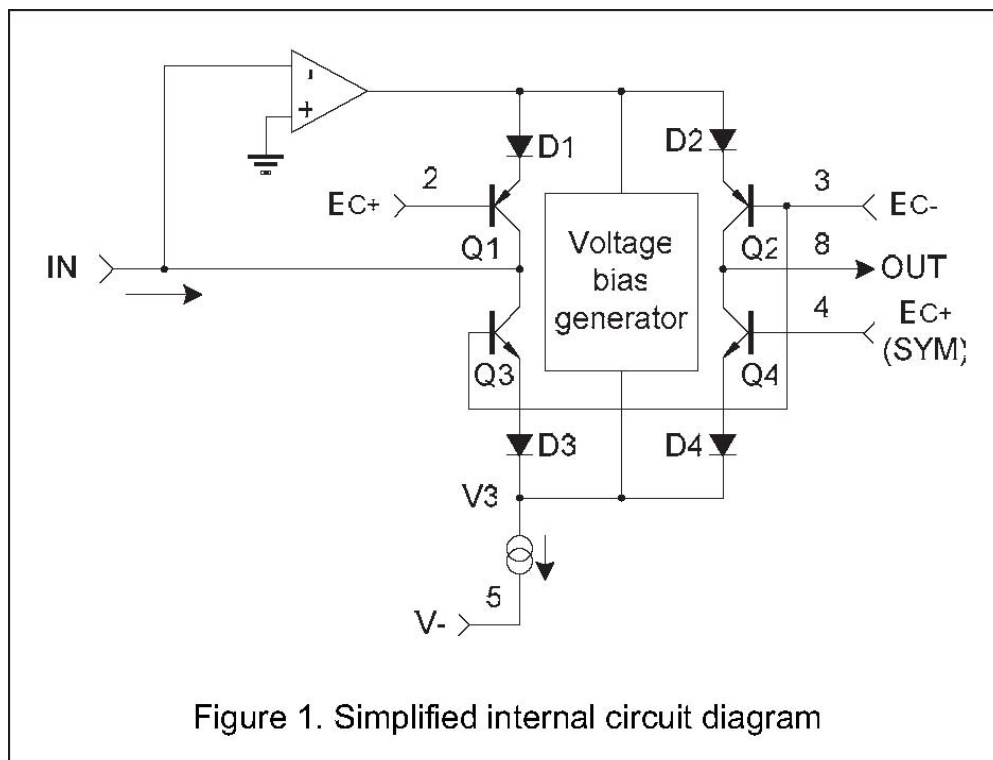

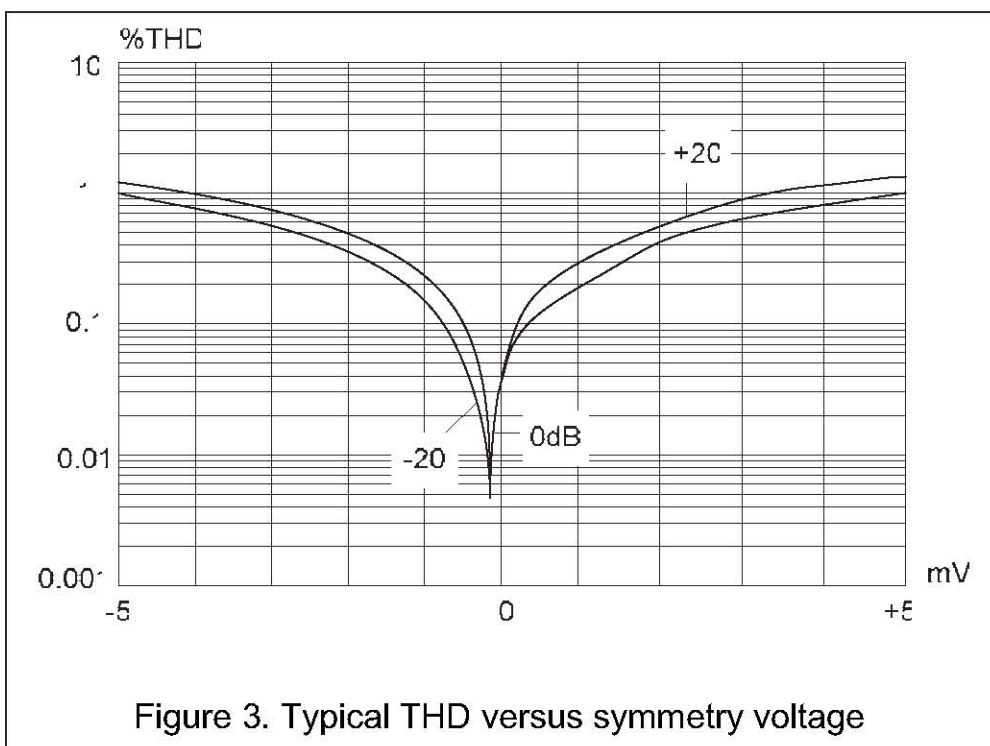
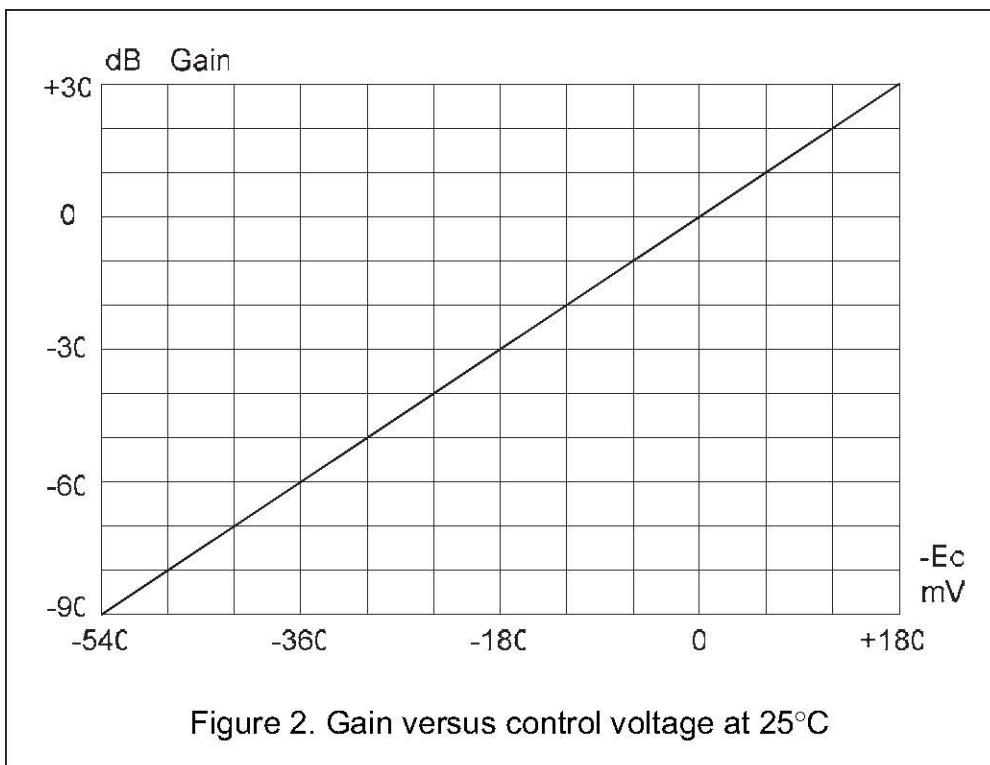

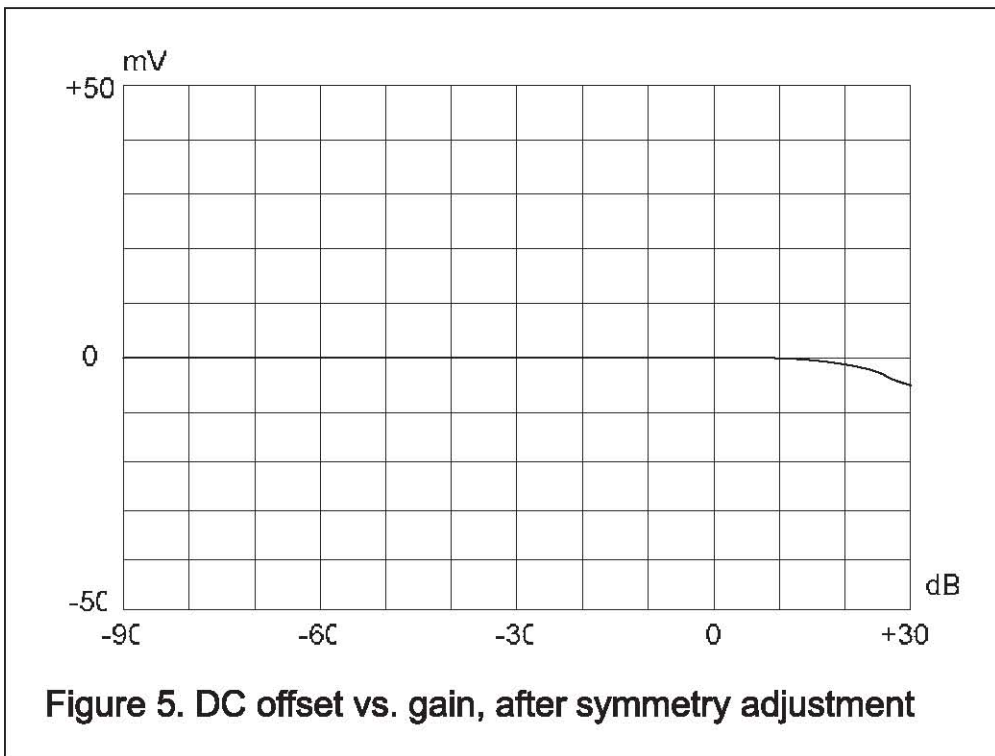
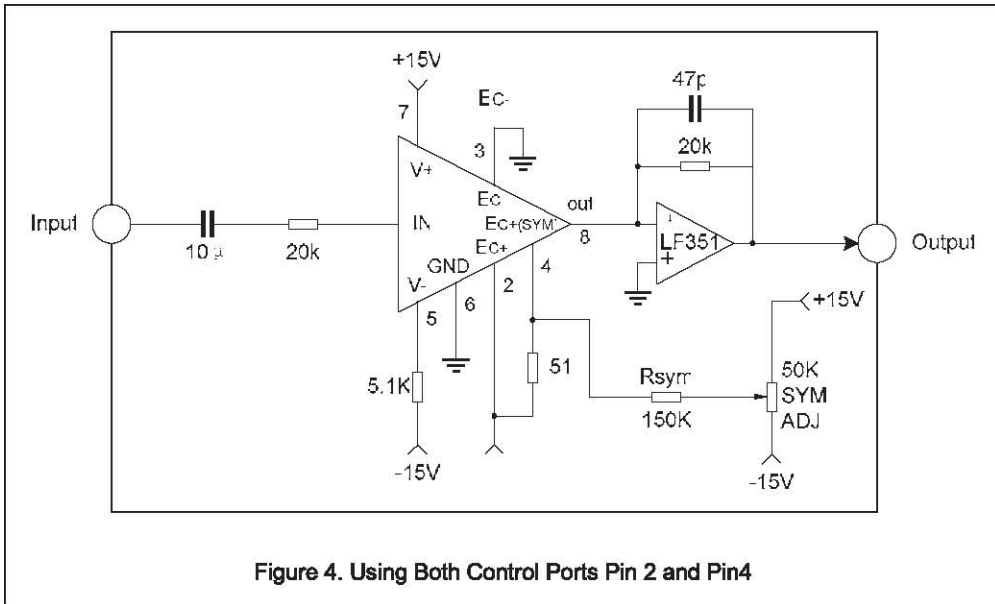

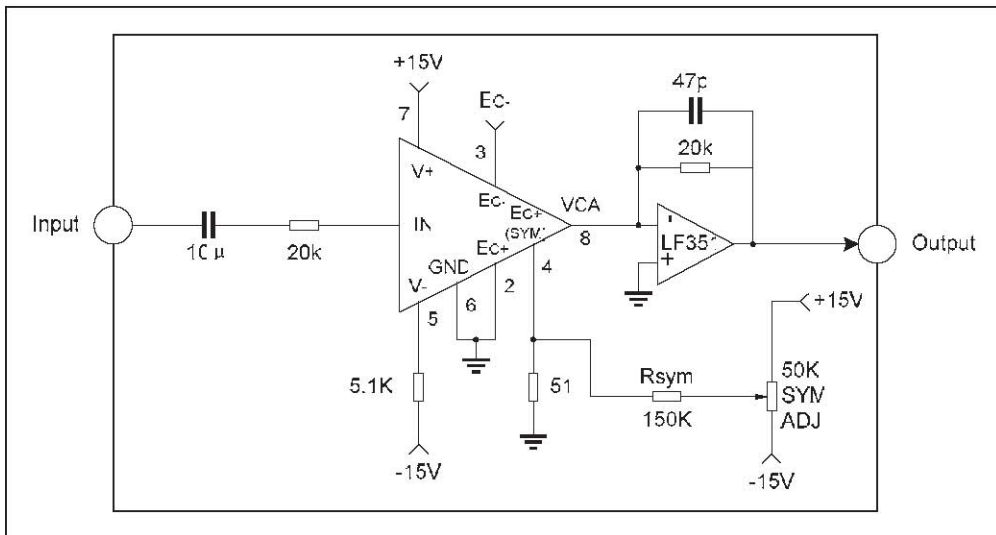
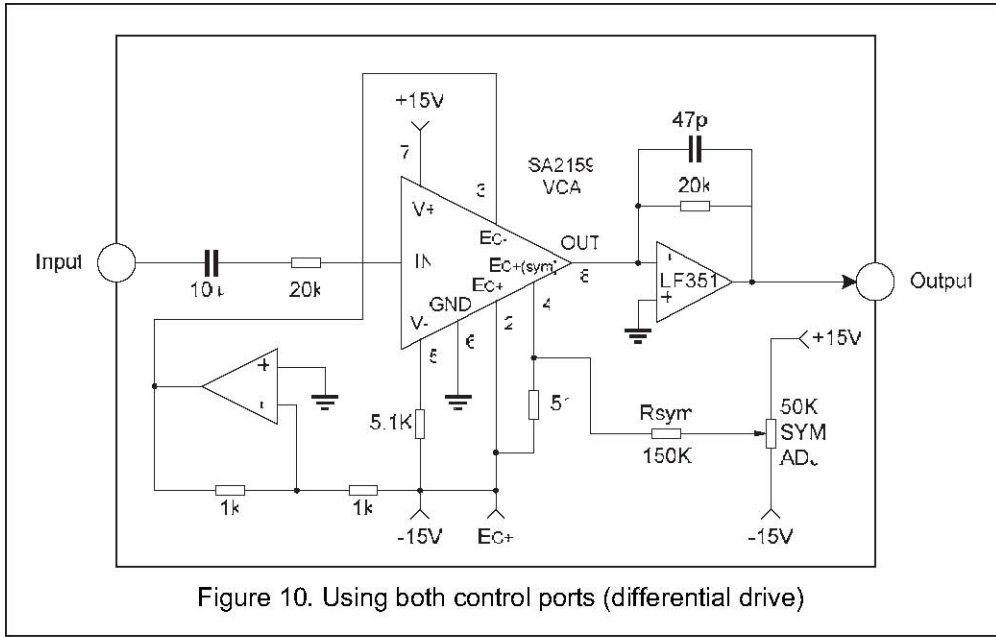

## 6. Stick Packaging

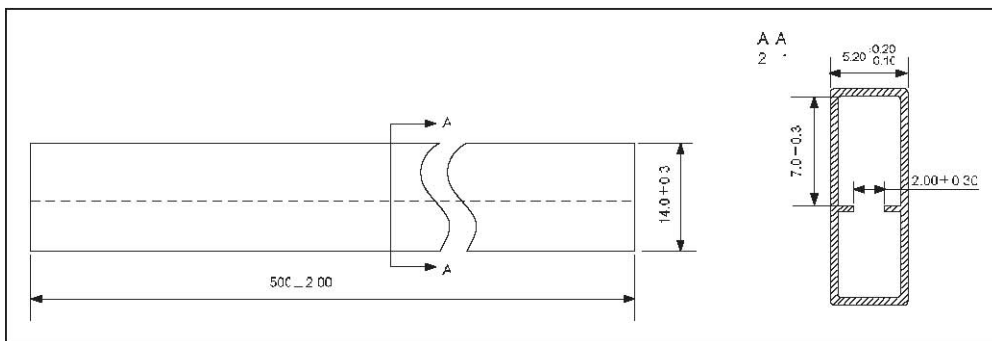

**7、Soldering**

MAX. Temperature (Surface) : Below 260°C

MAX. Temperature Duration : ≤ 10s

Above 220° C Duration : ≤ 30s

Between 150°C and 180°C : 60-120s

Duration Soldering Times : 2 Times

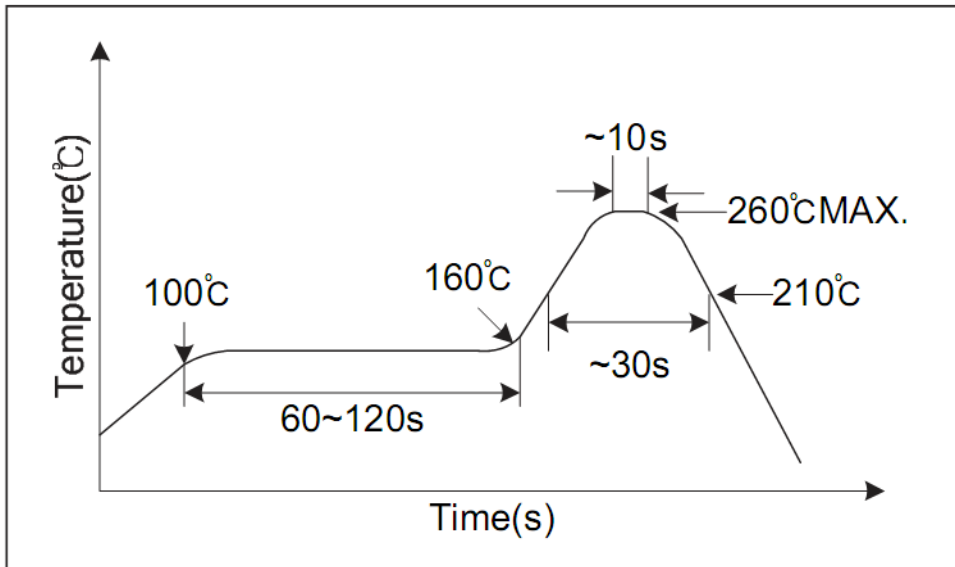

**8、Package Dimensions**

MAX. Temperature (Surface) : Below 260°C

MAX. Temperature Duration : <10s

Pre-heat Temperature : 120°C

Soldering Times : 1 Time

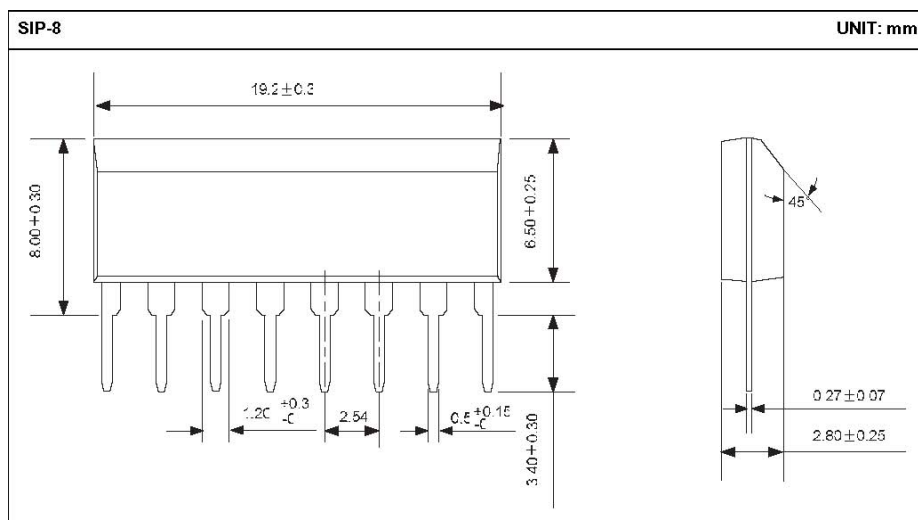

Name of the Part	Material Weight (mg/unit)	Material Name	Material Analysis (element)	Material Analysis (weight%)	Prohibited Content in total (ppm)
Leadframe	122	Cu-Alloy	Cu Fe Zn Pb	>97% 2.1-2.6% 0.05-0.2% <0.03%	<47
Plastic	633	Epoxy Resin	SiO2 Epoxy Sb2O3	70-90% 8-12% 1-3%	
Chip	7	Doped Silicon	Si Al	99.6% 0.4%	
Die attach material	0.5	Glue	Ag Epoxy Resin	82% 18%	
Wires	0.5	Gold	Au	99.99%	
Leads finishing	12.5	Sn Solder Ball	Sn Pb Cd	>99.9% <0.02% <0.0005%	<3 <0.1